



M1

DRY TRIMMER

Assembly Instructions

OVERVIEW

NOTE

The M1 dry trimmer does not require any tools, it is held together by tension. During assembly of the dry trimmer, there will be steps that require the assembler to pull or push on a component to ensure a snug and tight fit.

QUESTIONS?

SERVICE

MONDAY-FRIDAY
7:30AM - 4:30PM PST
(619) 455-8052

SERVICE@GREENBROZ.COM

WWW.GREENBROZ.COM/CUSTOMER-SUPPORT/

ASSEMBLY VIDEO

WWW.GREENBROZ.COM/DRY-TRIMMERS/M1

PARTS

1	GBZ-53-019	M1 CENTER FINNS	1
2	GBZ-H-0016	10-24 THUMB SCREW	1
3	GBZ-H-0255	HUB KEY	1
4	GBZ-53-016	M1 HUB HANDLE	1
5	GBZ-53-020	FORMED MANUAL DOOR	1
6	GBZ-53-017	DOOR FRAME	1
7	GBZ-53-012	M1 BARREL	1
8	GBZ-53-015	M1 TOP TRIMMING BLADE	1
9	GBZ-53-018	M1 TEFLON RING	1
10	GMP-53-014	M1 BOTTOM TRIMMING BLADE	1
11	GBZ-53-013	M1 MOTOR COVER 18GA	1
12	GBZ-E-0071	BROTHER GEARMOTOR (GF15N060_BWMRF2N)	1
13	GBZ-53-011	MOTOR MOUNT 11GA	1
14	GBZ-53-008	M1 TRIM CATCH	1
15	GBZ-53-005	LEFT SIDE PANEL	1
16	GBZ-53-006	RIGHT SIDE PANEL	1
17	GBZ-53-007	M1 TRIM CATCH MOUNT	1
18	GBZ-H-0105	1/2-13 THREADED STEM SMART CASTER	4
19	GBZ-53-EBOX	M1 E-BOX	1
20	GBZ-53-010	CHUTE COVER	1
21	GBZ-53-009	M1 CHUTE RAMP	1
22	GBZ-53-022	M1 CART WELDMENT	1
35	GBZ-53-021	M1 LID	2
36	GBZ-53-	FIN LOCKING KEY	1

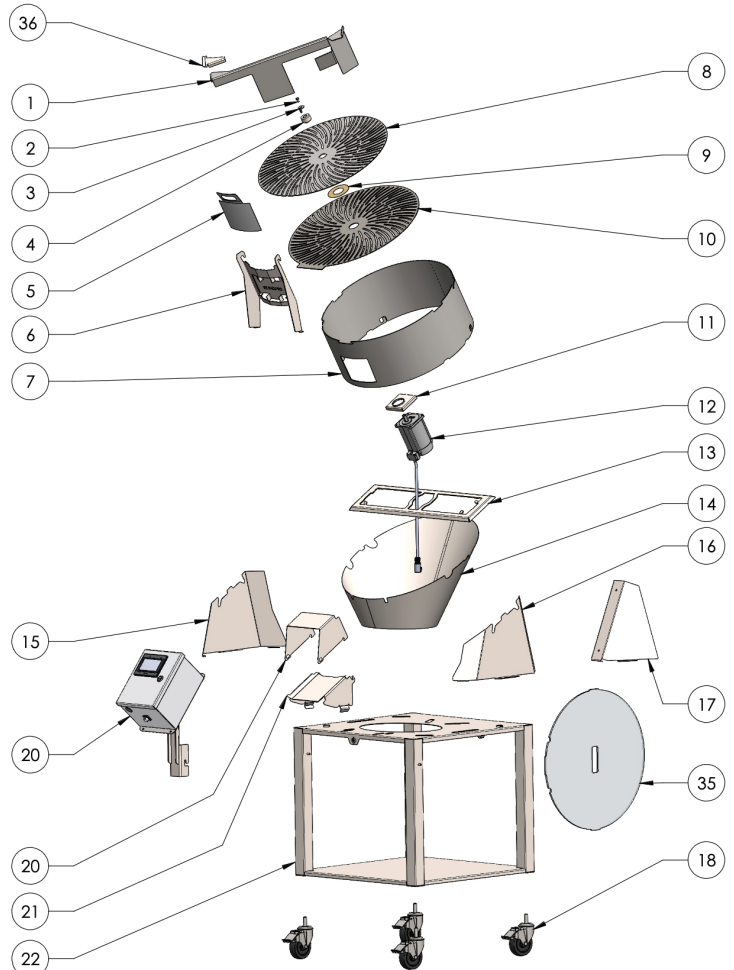

PANELS

PARTS

15	GBZ-53-005	LEFT SIDE PANEL	1
16	GBZ-53-006	RIGHT SIDE PANEL	1
17	GBZ-53-007	M1 TRIM CATCH MOUNT	1

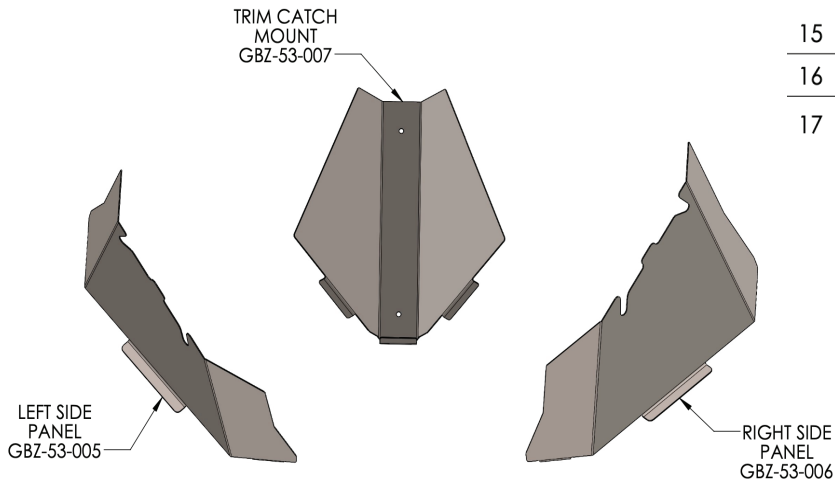

TOP DOWN VIEW

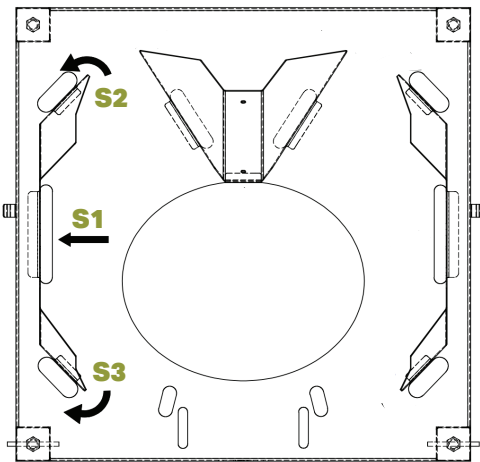

LEFT SIDE PANEL INSTALL

1. Slide the center and rear tab of the left side panel into slots labeled **S1** and **S2**.
2. Flex front of left side panel to pass through slot labeled **S3**.

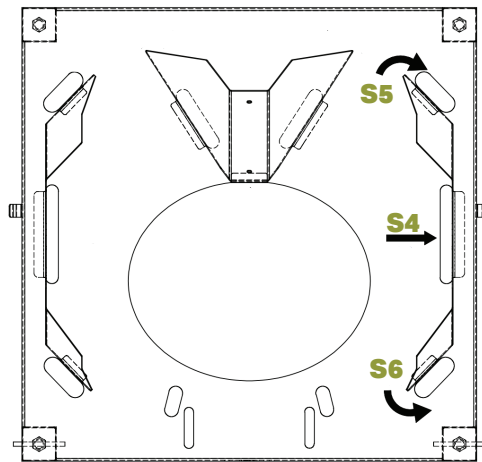

RIGHT SIDE PANEL INSTALL

1. Slide the center and rear tab of the right side panel into slots labeled **S4** and **S5**.
2. Flex front of right side panel to pass through slot labeled **S6**.

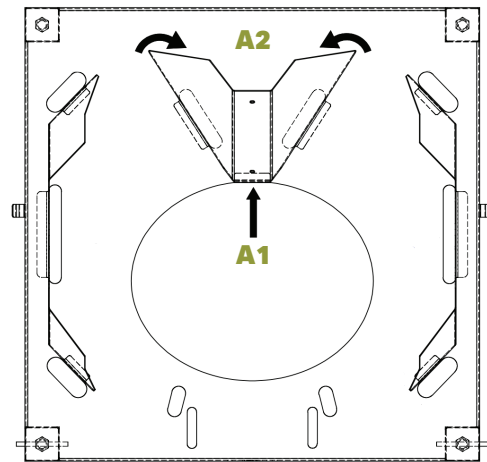

TRIM CATCH MOUNT INSTALL

1. Slide front tab onto frame at arrow **A1**.
2. Flex together and pass through slots as shown at label **A2**.

FINAL ASSEMBLY

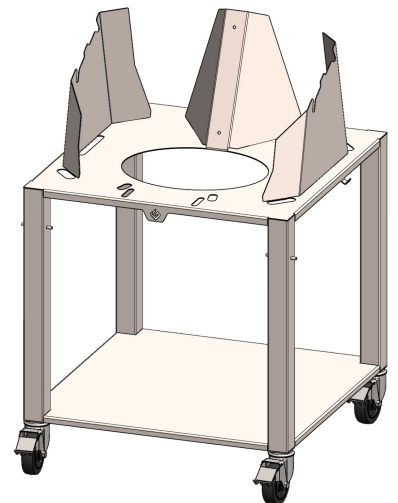

TRIM CATCH

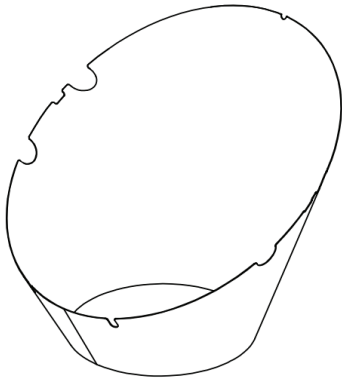

TRIM CATCH
GBZ-53-008

PARTS

14

GBZ-53-008

M1 TRIM CATCH

1

TRIM CATCH INSTALL

1. Angle trim catch as shown.
2. Ensure **studs** pass through holes as shown in diagram **D1** at points **P1**
3. Press firmly at point labeled **A3** and compress the trim catch to fit into the top of the cart.

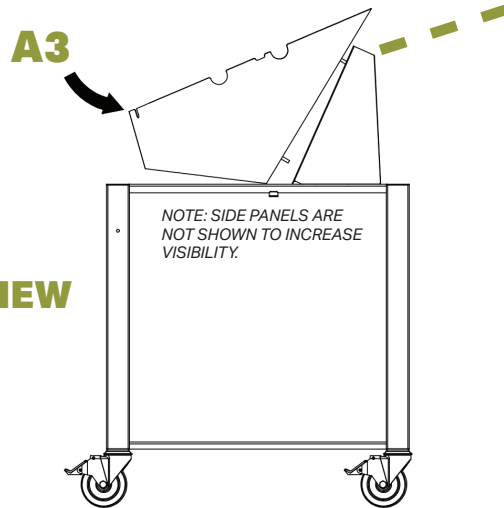

RIGHT SIDE VIEW

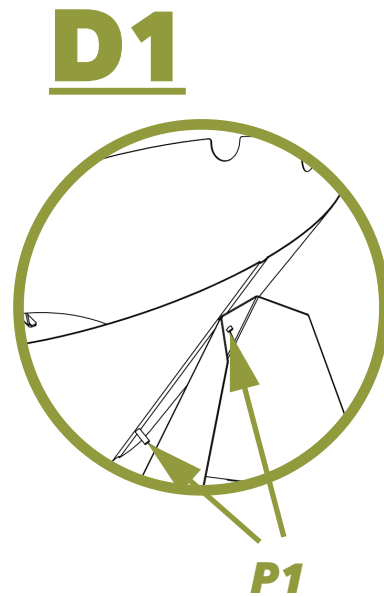

FINAL ASSEMBLY

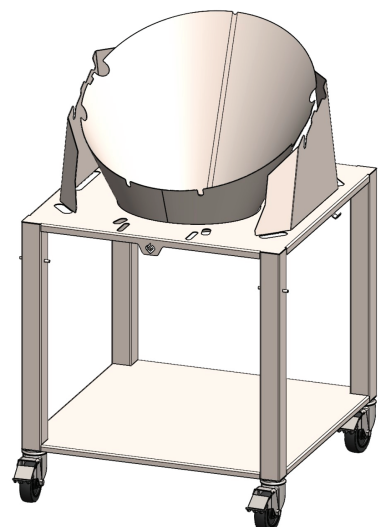

BUD CHUTE

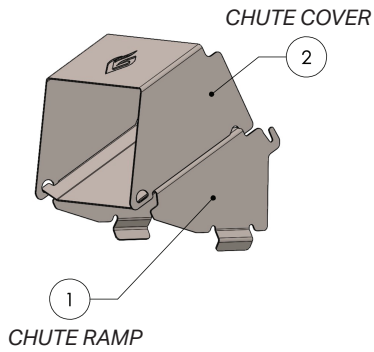

PARTS

20	GBZ-53-010	CHUTE COVER	1
21	GBZ-53-009	M1 CHUTE RAMP	1

BUD CHUTE ASSEMBLY

1. Hook chute cover into chute ramp at location labeled **A4**.
2. Flex chute cover at points labeled **A5**.
3. Ensure tabs of chute ramp pass through chute cover as shown in diagram **D2** at point **P2**.

D2

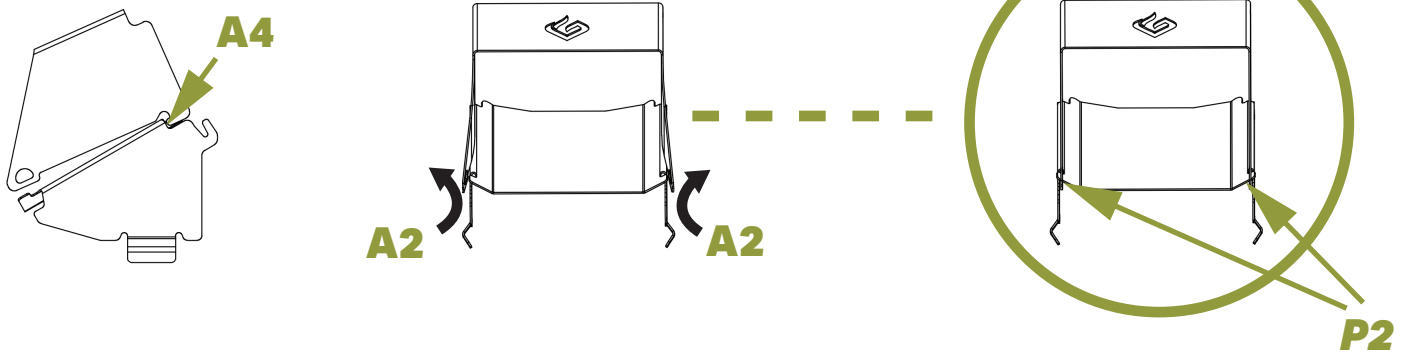

BUD CHUTE INSTALL

1. Press firmly down on bud chute assembly to slide tabs at point **P3** into slots in top frame labeled **S8**.
2. Ensure fitment as shown in diagram **D3**

D3

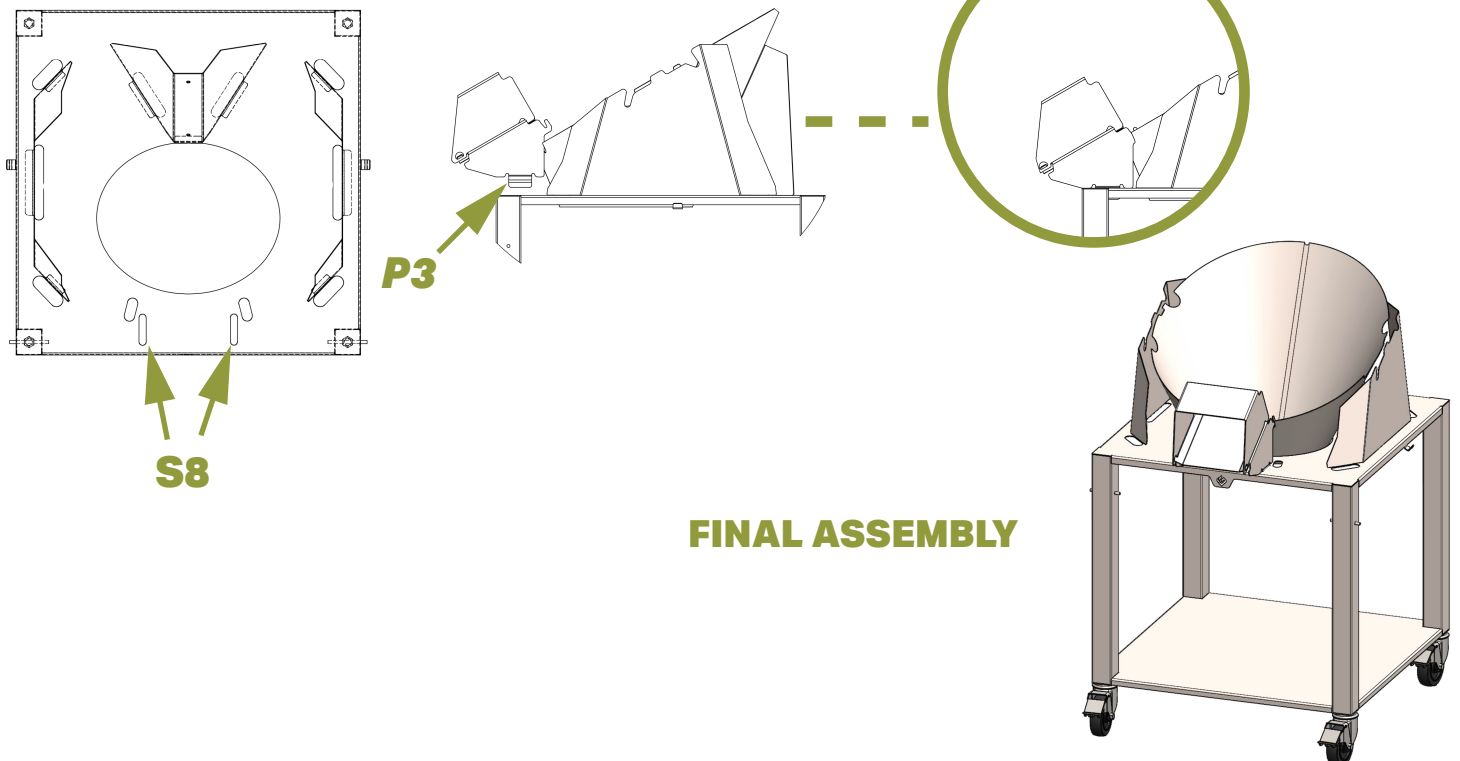

MOTOR

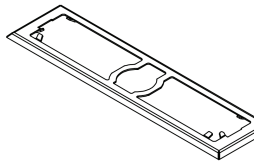

MOTOR MOUNT
GBZ-53-011

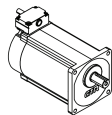

BROTHER GEARMOTOR
GBZ-53-0071

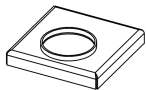

M1 MOTOR COVER
GBZ-53-013

PARTS

11	GBZ-53-013	M1 MOTOR COVER 18GA	1
12	GBZ-E-0071	BROTHER GEARMOTOR (GF15N060_BWMRF2N)	1
13	GBZ-53-011	MOTOR MOUNT 11GA	1

MOTOR MOUNT INSTALL

1. Slide motor mount into side panels and trim catch at labels **P4**, and as rotated as shown in diagram **D4**.
2. Rotate motor mount until flat on side panels as shown in diagram **D5**.
3. Ensure side panel tabs pass through inside of motor mount as shown in diagram **D6** and arrow **A7**.



P4

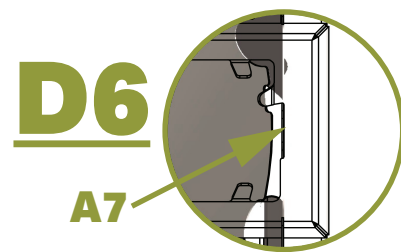
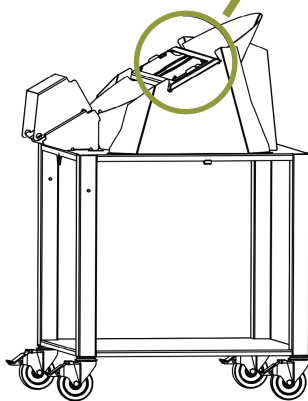
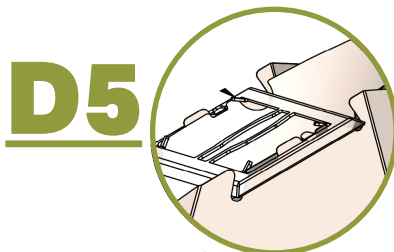
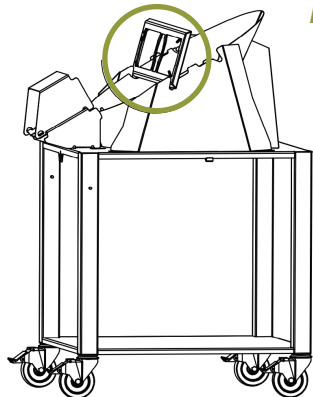

A7

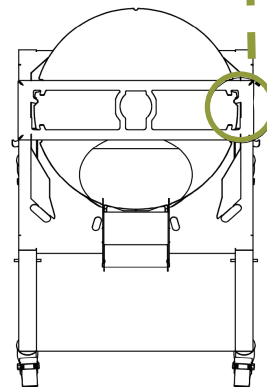

MOTOR INSTALL

1. Feed motor power cable and motor through motor mount hole at point **P5**.
2. Slide motor cover onto motor as shown in diagram **D7**.

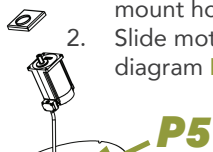

P5

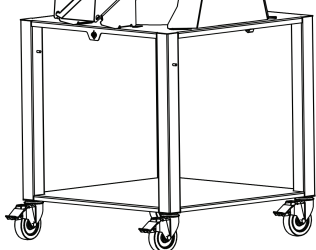

D7

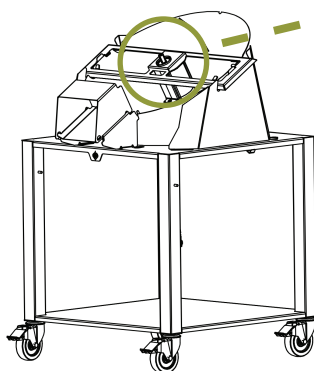
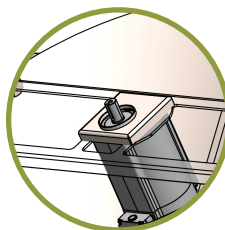

BARREL

PARTS

7

GBZ-53-012

M1 BARREL

1

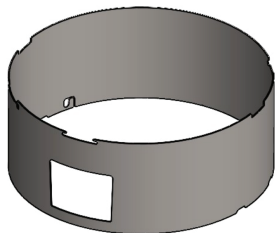

M1 BARREL
GBZ-53-012

BARREL INSTALL

1. Lower barrel onto motor mount at indicated angle at label **A8**.
2. Ensure barrel fits into motor mount as shown in diagram **D8** and at points labeled **P9**.

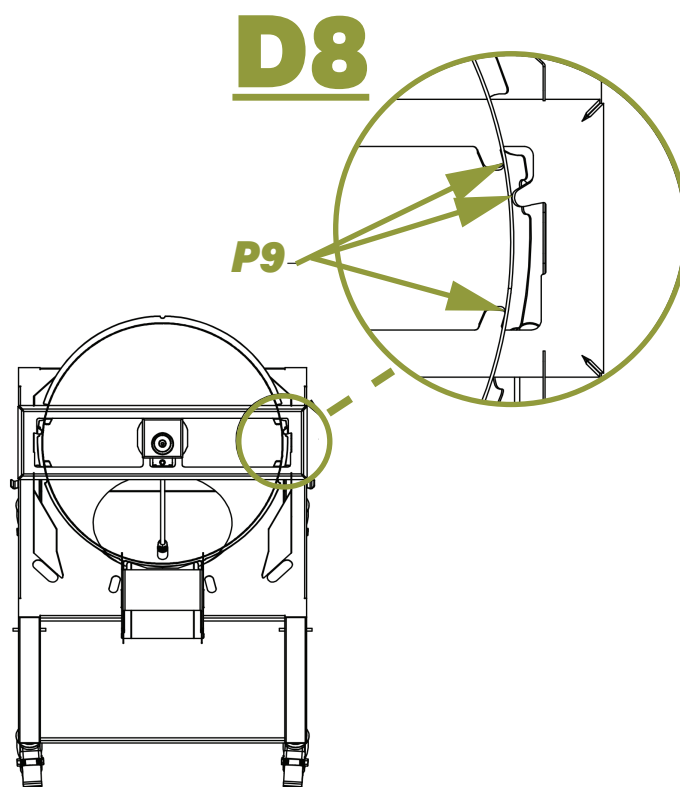
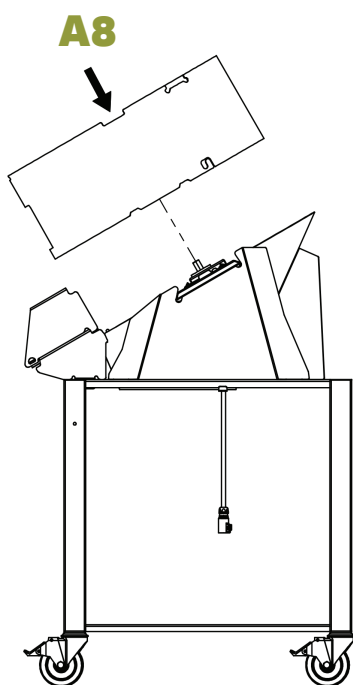

DOOR FRAME

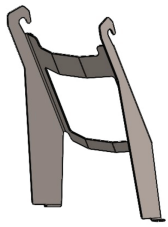

M1 DOOR FRAME
GBZ-53-017

PARTS

6

GBZ-53-017

DOOR FRAME

1

DOOR FRAME INSTALL

1. Lower door frame down as shown at arrow **A8**.
2. Fit door frame into area between the barrel and ramp cover as shown at arrow **A9** in diagram **D9**.
3. Compress door frame on both sides as indicated at arrow **A10**.
4. Slide door frame down into slots labeled **S10** until tabs at arrow **A10** pass through slots.
5. Ensure door frame hooks over the barrel as diagram **D10** indicates at points **P5** and tabs are secured on **both** sides as indicated at **A11**.

A8

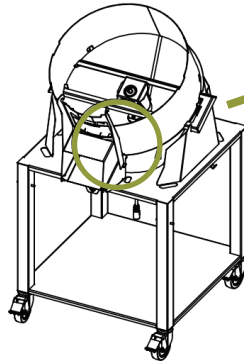
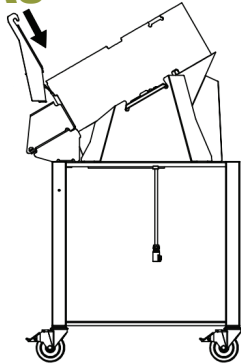

D9

A9

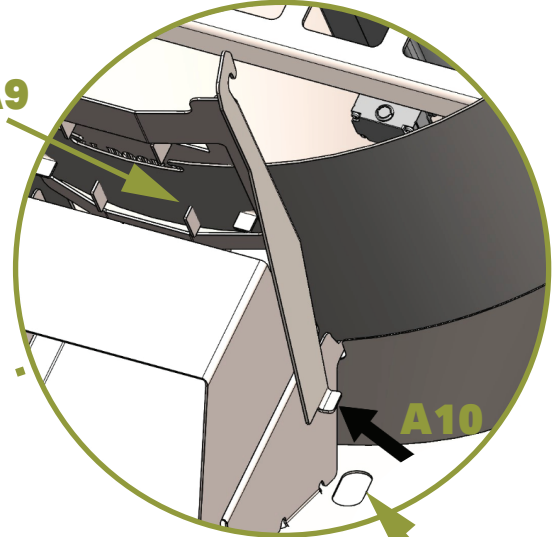

A10

S10

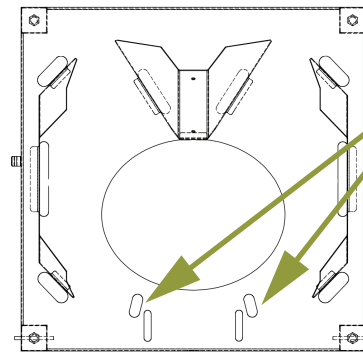

TOP DOWN VIEW

NOTE: SOME PARTS ARE HIDDEN TO INCREASE VISIBILITY.

D10

P5

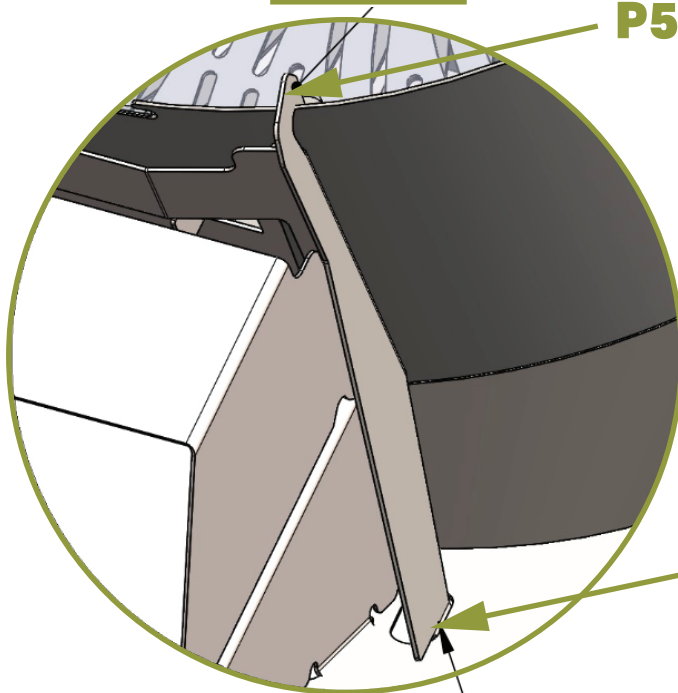

A11

FINAL ASSEMBLY

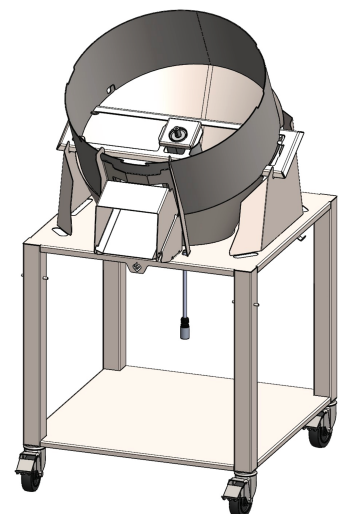

DOOR AND BOTTOM BLADE

PARTS

10 | GMP-53-014 | M1 BOTTOM TRIMMING BLADE | 1

BOTTOM BLADE INSTALL

1. Lower bottom blade into barrel as shown at **A12**.
2. Ensure bottom blade tab point **P6** fits through bud chute at arrow **A14**.
3. Ensure motor drive shaft labeled **A4** passes through bottom blade.

PARTS

5 | GBZ-53-020 | FORMED MANUAL DOOR | 1

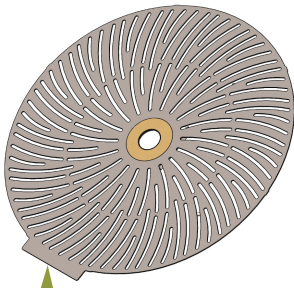

NOTE: TOP OF BOTTOM BLADE INDICATED BY TEFLON RING AND "S" SHAPE OF BLADE.

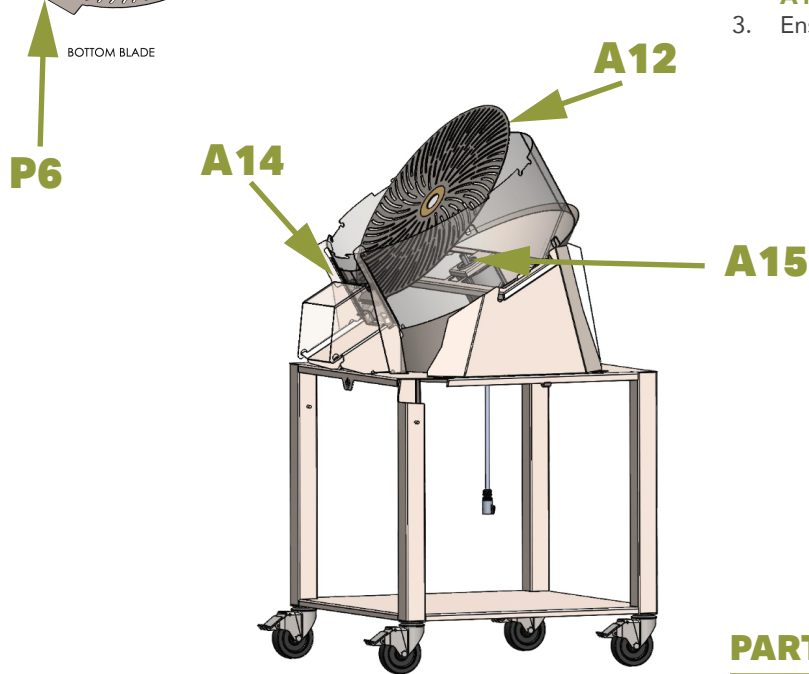

DOOR INSTALL

1. Lower door into position at angle labeled **A16**.
2. Slide door into space between door frame and barrel as shown at arrow **A17** in diagram **D11**.

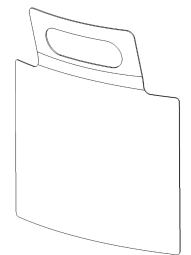
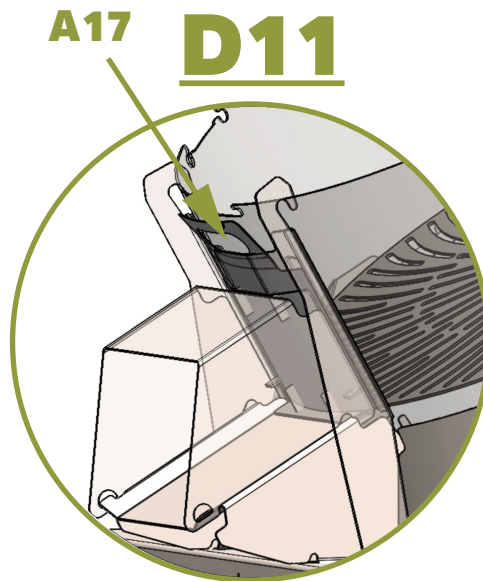
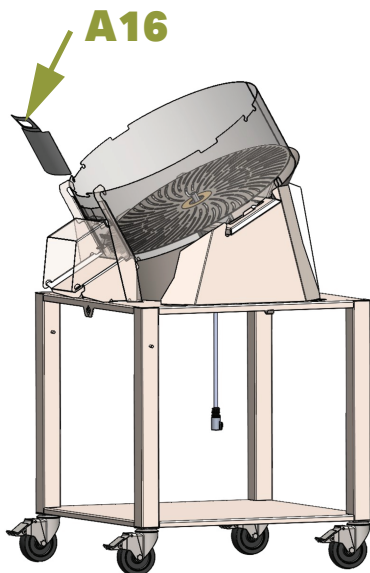

DOOR
GBZ-53-020

TOP BLADE AND HUB

NOTE: TOP BLADE CORRECT ORIENTATION IS INDICATED BY BLADE PATTERN IN A "REVERSE S", OPPOSITE OF BOTTOM BLADE.

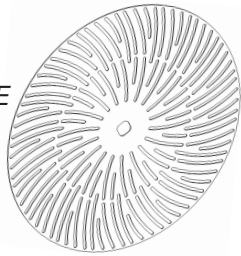

TOP BLADE
GBZ-53-015

PARTS

2	GBZ-H-0016	10-24 THUMB SCREW	1
3	GBZ-H-0255	HUB KEY	1
4	GBZ-53-016	M1 HUB HANDLE	1
8	GBZ-53-015	M1 TOP TRIMMING BLADE	1

NOTE: INSTALL DOOR PRIOR TO TOP BLADE INSTALLATION FOR EASIER INSTALL.

TOP BLADE INSTALL

1. Lower top blade into barrel at indicated angle **A18**.
2. Rotate top blade around until point **P7** of the hub handle fits into center of top blade at arrow **A19** in diagram **D12**.
3. Rotate hub handle and top blade around until point **P8** of hub handle aligns with motor key way point **P9** as shown in diagram **D13**.
4. Slide hub key into slot in hub and motor drive shaft **P0**.
5. Screw in thumb screw into drive at point **P10**.

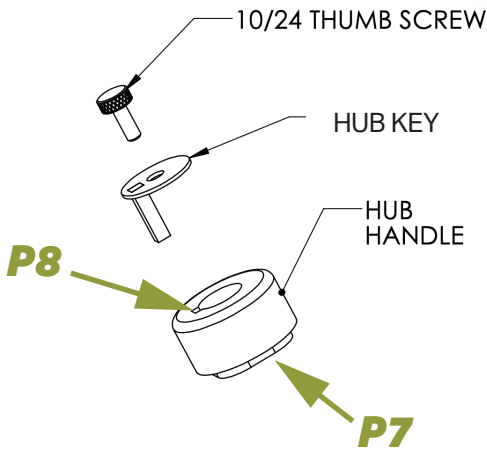

D12



D13

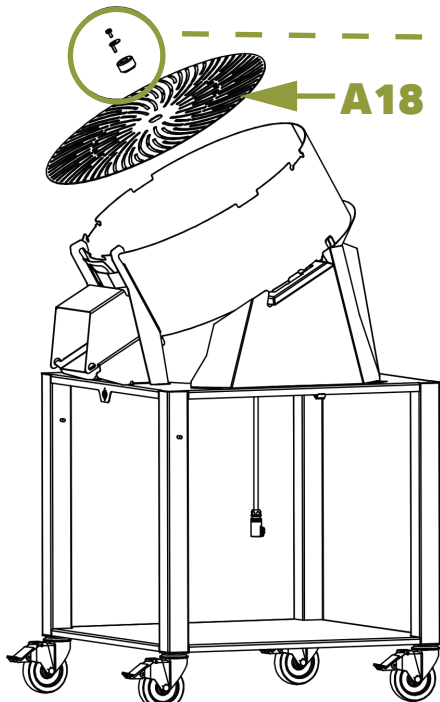
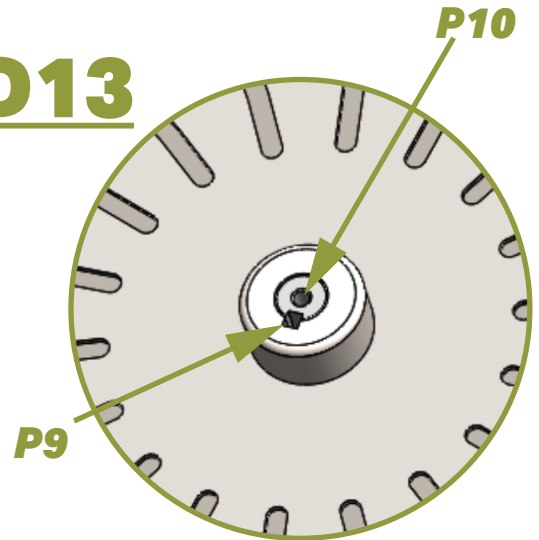

FINAL ASSEMBLY

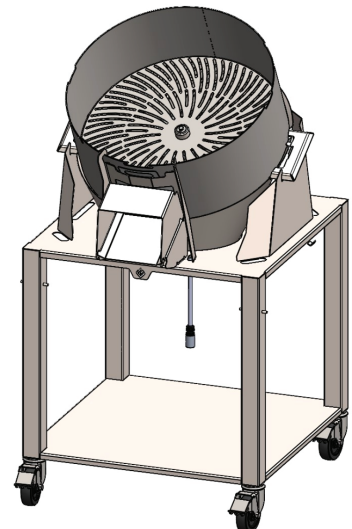

CENTER FIN

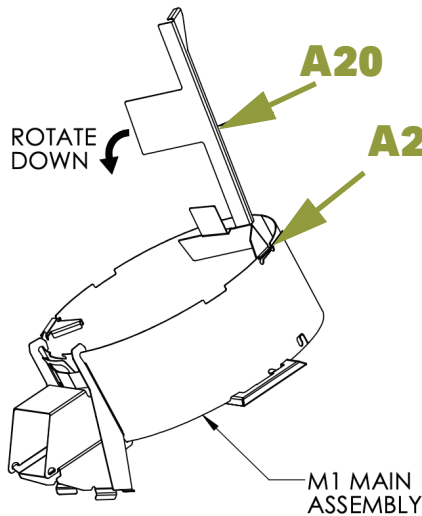
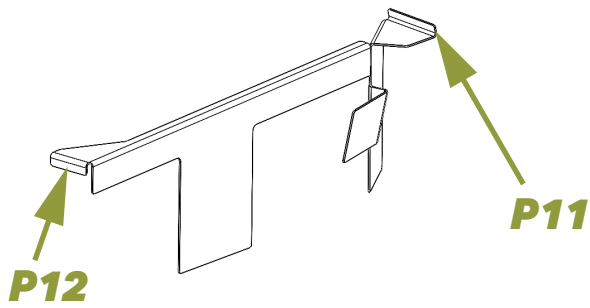

PARTS

1	GBZ-53-019	M1 CENTER FIN	1
---	------------	---------------	---

CENTER FIN INSTALL

1. Hook point **P11** of center fin into barrel at arrow **A21** in orientation shown at arrow **A20**.
2. Rotate center fin down to latch point **P12** of center fin onto point **P13** of barrel as shown in diagram **D14**.

D14

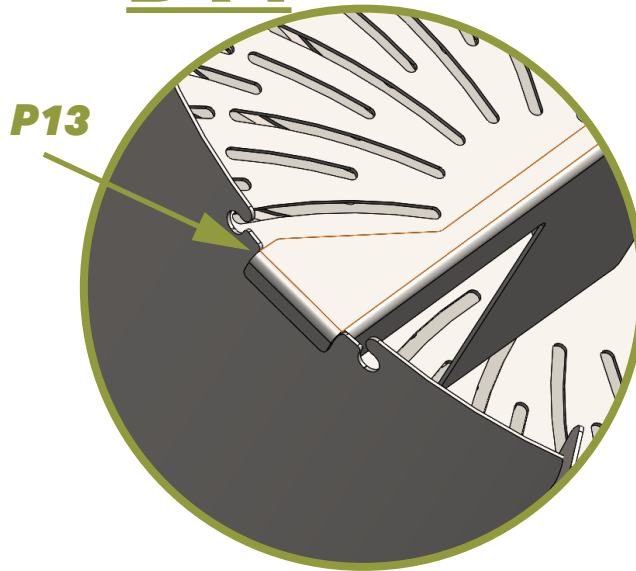

PARTS

36	GBZ-53-	FIN LOCKING KEY	1
----	---------	-----------------	---

CENTER FIN LOCKING KEY INSTALL

1. Slide center fin key into position shown at arrow **A22**.
2. Slide center fin key point **P14** into section on the barrel as shown in diagram **D15** at arrow **A23**.
3. Rotate center fin key down into locking position indicated at **A24** in diagram **D16**.

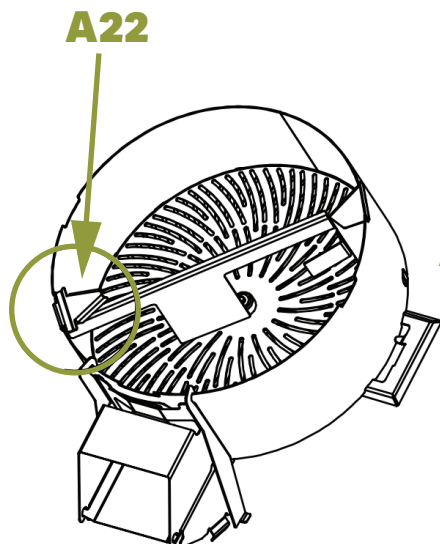

D15

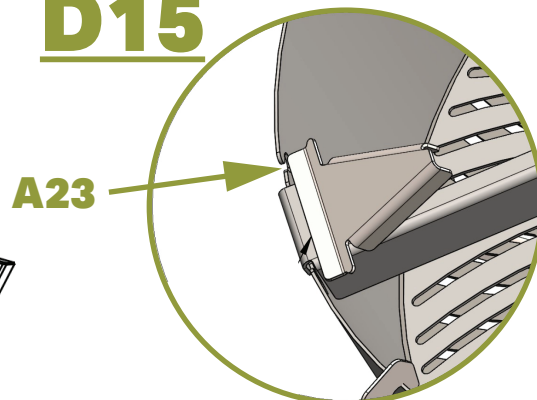

D16

